

DIMENSIONS	QS7.5TD-260	QS11TD-260	QS15TD-260
A	1800mm	1800mm	1800mm
B	1370mm	1640mm	1640mm
C	980mm	1000mm	1000mm
D	640mm	750mm	750mm
E	1" BSPF	1" BSPF	1" BSPF
F	350mm	460mm	510mm
G	1150mm	1240mm	1265mm

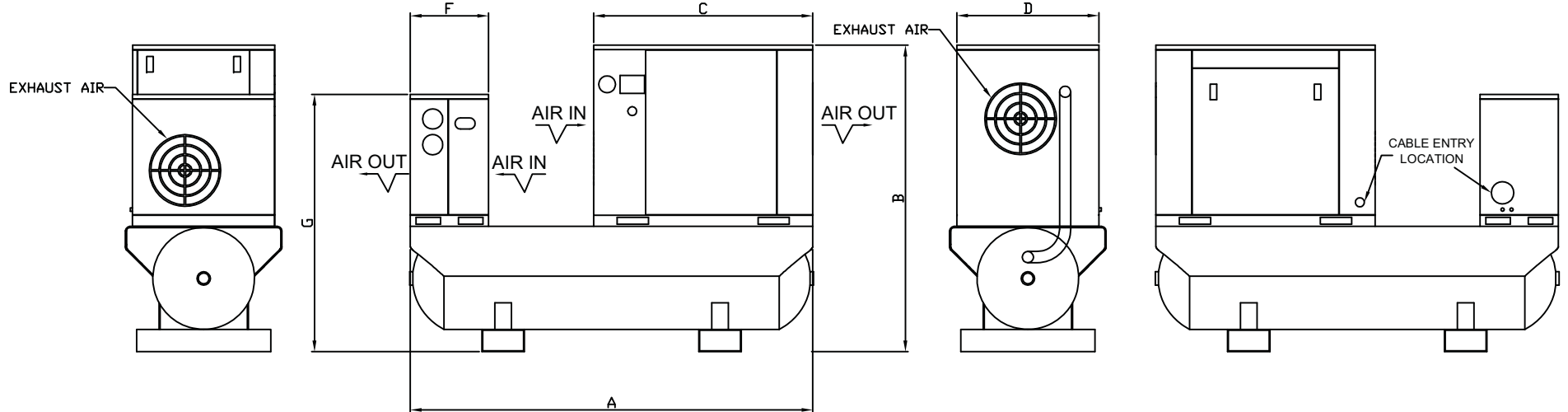

Rev	Description	By	Date
A	1ST ISSUE	N.W.	30.01.09

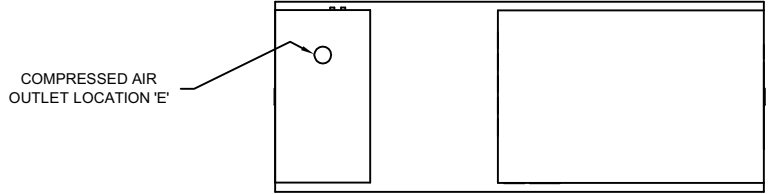
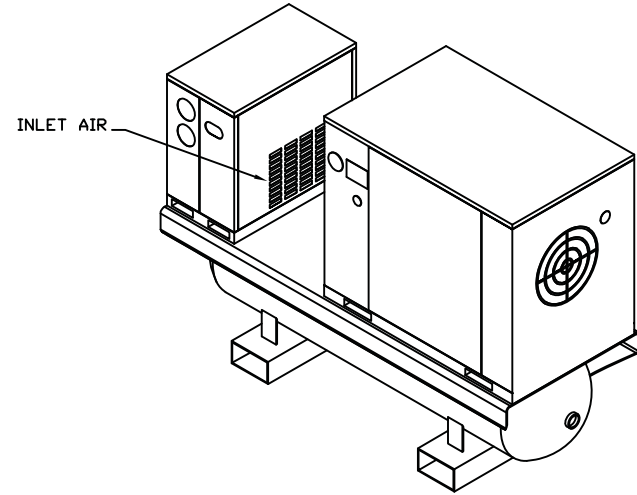

Quantum Air Compressors
 Phone: 1300 308 717
 Fax: 1300 660 922
 E-mail: service@quantum.net.au
 Postal Address: PO Box 732, Clebe, NSW 2037
 ABN: 62 121 508 932

QS7.5 Rotary Screw Air Compressor
 QS11 Rotary Screw Air Compressor
 QS15 Rotary Screw Air Compressor

DATE: 21.01.2009
 DRN: adup.com.au
 CPO: 41
 SCALE: N.T.S.

Q5 A