

DRAWING No: Q23 ISSUE: A

DIMENSIONS	QSD15TTD-1600	QSD22TTD-1600	QSD30TTD-1600
A	1910mm	1910mm	1910mm
B	1680mm	1950mm	1950mm
C	1600mm	1600mm	1600mm
D	1" BSPF	1" BSPF	1" BSPF

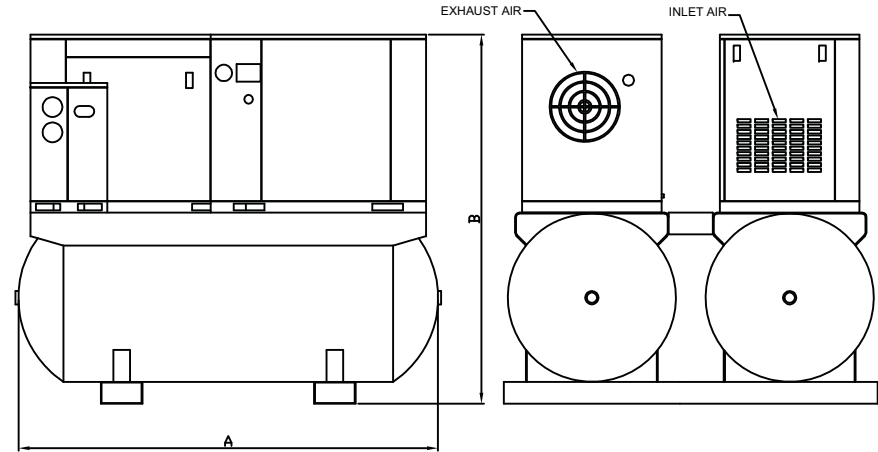

Rev	Description	By	Date
A	1ST ISSUE	N.W.	30.01.09

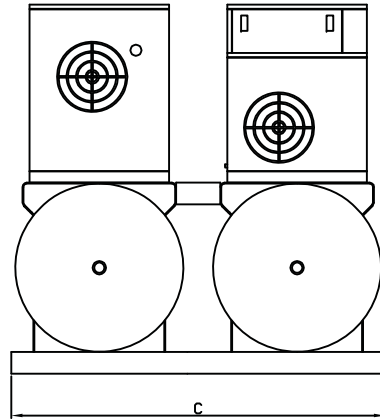
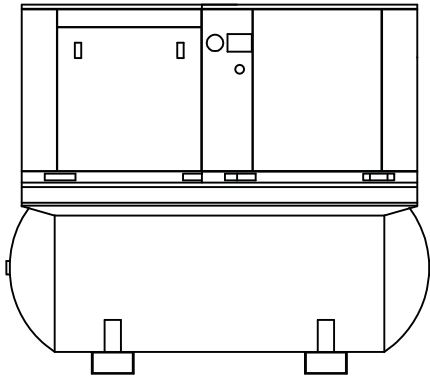
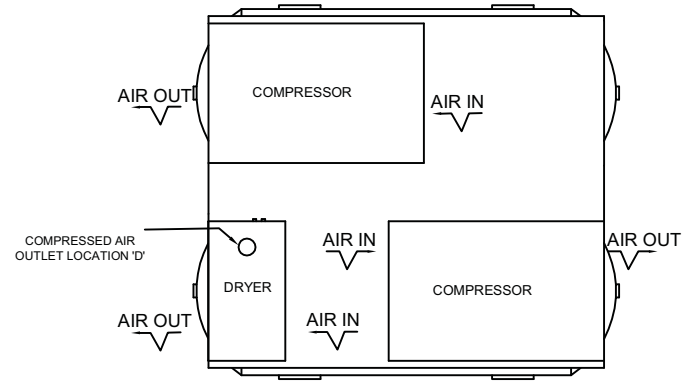
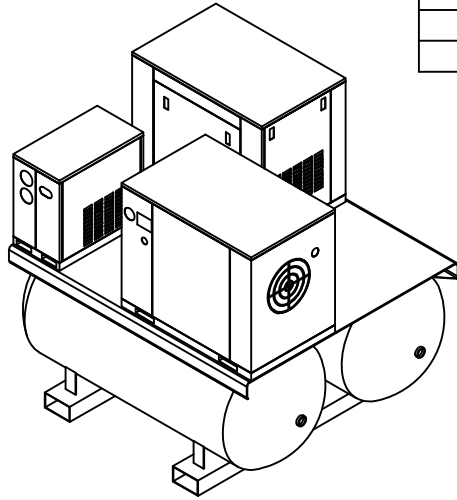

Quantum Air Compressors  
 Phone: 1300 308 717  
 Fax: 1300 660 922  
 E-mail: [service@quantum.net.au](mailto:service@quantum.net.au)  
 Postal Address: PO Box 732, Clebe, NSW 2037  
 ABN: 62 121 508 932

QS7.5 Duplex Rotary Screw Air Compressor  
 QS11 Duplex Rotary Screw Air Compressor  
 QS15 Duplex Rotary Screw Air Compressor  
 DATE: 19.01.2009  
 DRN: [adup.com.au](http://adup.com.au)  
 CNO: 41  
 SCALE: N.T.S.