

DRAWING No: Q2  
ISSUE: A

DIMENSIONS	QS7.5	QS11	QS15
A	980mm	1000mm	1000mm
B	640mm	750mm	750mm
C	810mm	1080mm	1080mm
D	530mm	600mm	600mm
E	1" BSPF	1" BSPF	1" BSPF

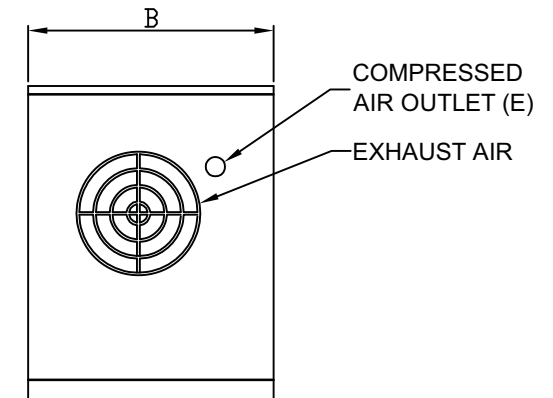

Rev	Description	By	Date
A	1ST ISSUE	N.W.	30.01.09

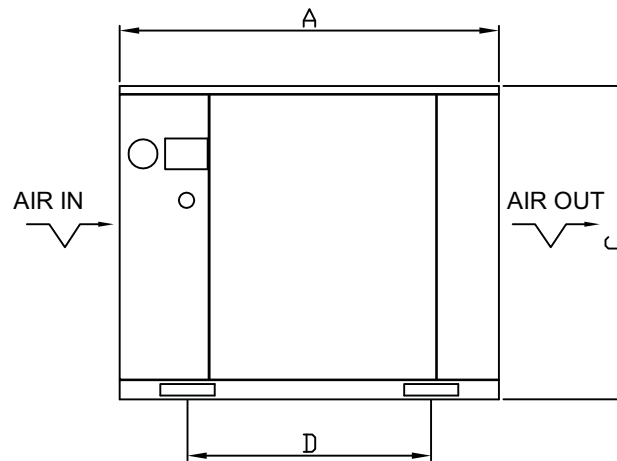
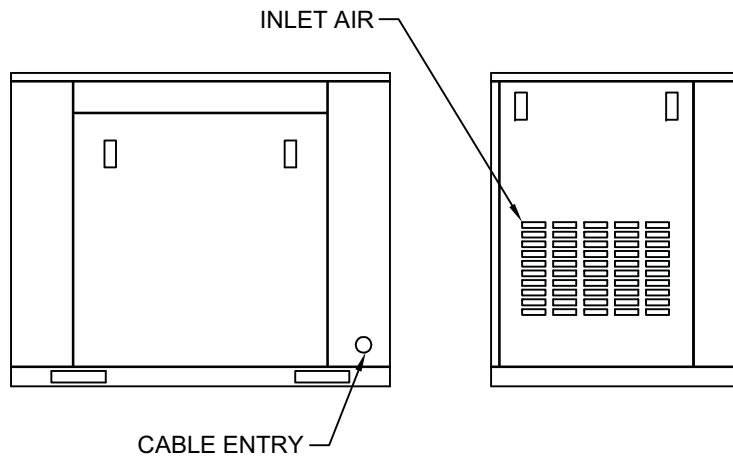
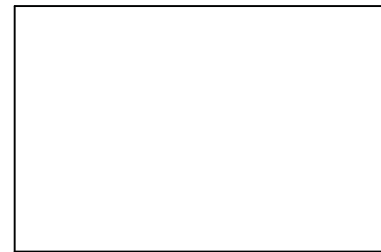
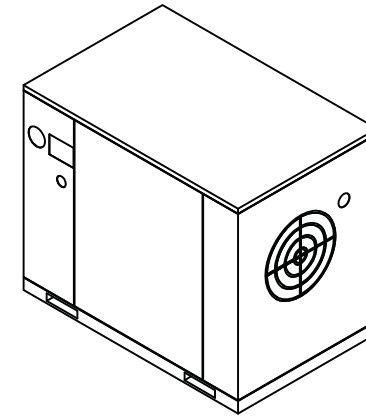

Quantum Air Compressors  
 Phone: 1300 308 717  
 Fax: 1300 660 922  
 E-mail: [service@quantum.net.au](mailto:service@quantum.net.au)  
 Postal Address: PO Box 732, Clebe, NSW 2037  
 ABN: 62 121 508 932

QS7.5 Rotary Air Screw Compressor  
 QS11 Rotary Air Screw Compressor  
 QS15 Rotary Air Screw Compressor

DATE: 22.01.2009  
 DRN: [adup.com.au](http://adup.com.au)  
 CPO: 41  
 SCALE: N.T.S.

Q2

A