

DIMENSIONS	QS7.5TD-800	QS11TD-800	QS15TD-800
A	1910mm	1910mm	1910mm
B	1680mm	1950mm	1950mm
C	980mm	1000mm	1000mm
D	640mm	750mm	750mm
E	1" BSPF	1" BSPF	1" BSPF
F	350mm	460mm	510mm
G	1460mm	1550mm	1580mm

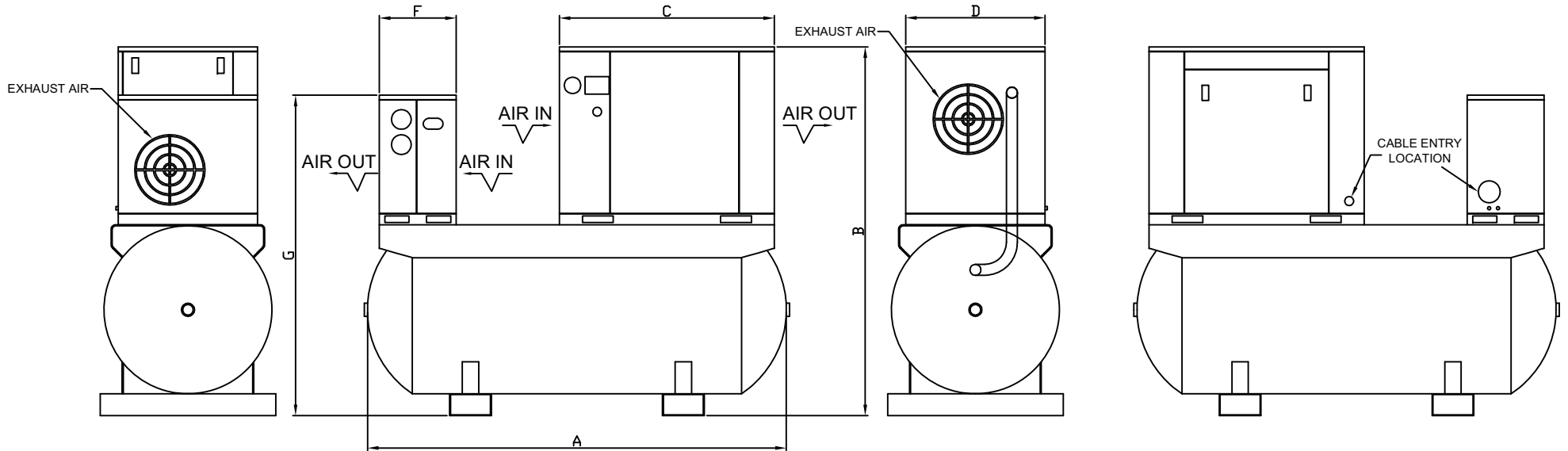

Rev	Description	By	Date
A	1ST ISSUE	N.W.	30.01.09

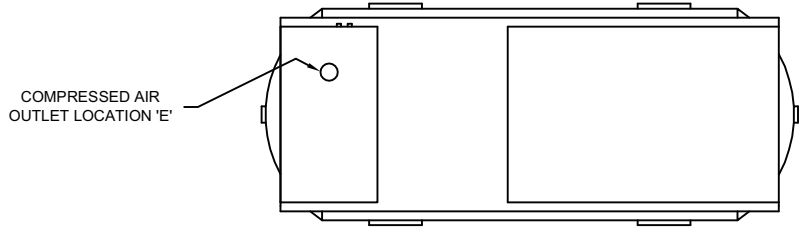
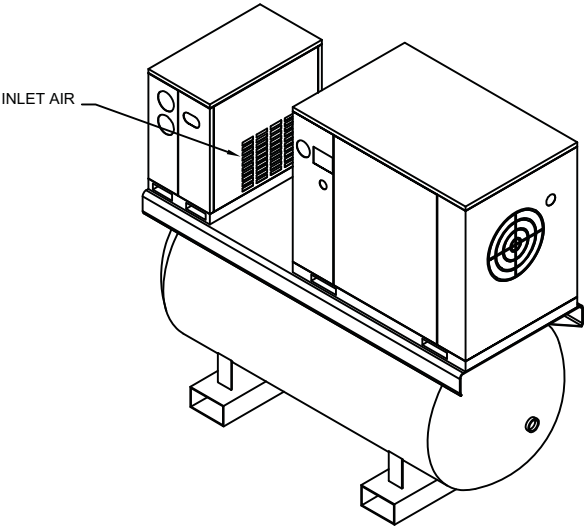

Quantum Air Compressors
 Phone: 1300 308 717
 Fax: 1300 660 922
 E-mail: service@quantum.net.au
 Postal Address: PO Box 732, Clebe, NSW 2037
 ABN: 62 121 508 932

QS7.5 Rotary Screw Air Compressor
 QS11 Rotary Screw Air Compressor
 QS15 Rotary Screw Air Compressor

DATE: 21.01.2009
 DRN: adup.com.au
 CPO: 41
 SCALE: N.T.S.

Q19